

Rod Ends Series K - Standard

Series GI

Rod Ends with female thread made from free-cutting or heat-treated steel, zinc plated and fitted with a grease nipple

Especially suited for axial loads

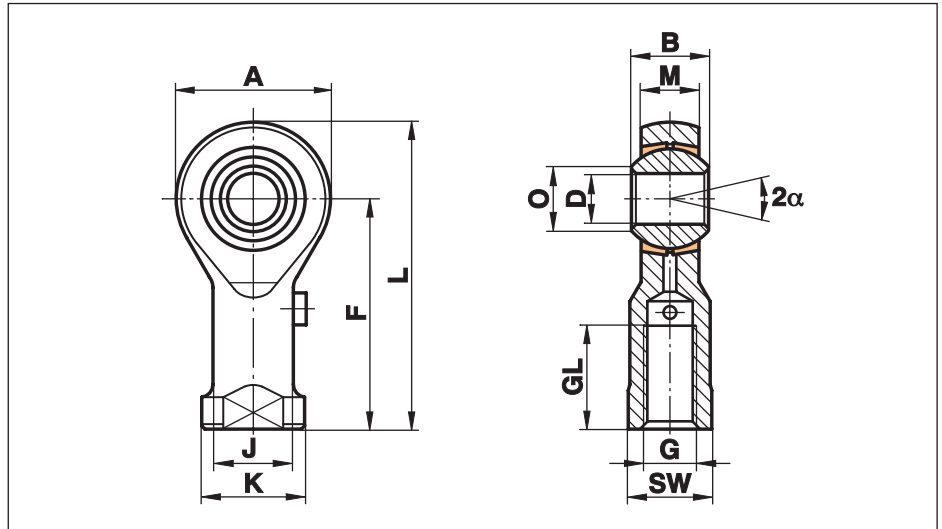

Size (D)	B	M	A	F	L	K	J	O	SW	G	GL	Static load C ₀ kN	Dynamic load C kN	Limiting speed rev/min	Weight g
5	8	6,00	18	27	36	11	9,0	7,7	9	M 5	10	9,9	2,5	900	18
6	9	6,75	20	30	40	13	10,0	8,9	11	M 6	12	11,9	3,2	760	27
8	12	9,00	24	36	48	16	12,5	10,4	13	M 8	16	17,1	5,4	620	46
10	14	10,50	28	43	57	19	15,0	12,9	17	M 10	20	21,4	7,5	500	76
12	16	12,00	32	50	66	22	17,5	15,4	19	M 12	22	27,0	10,0	450	115
14	19	13,50	36	57	75	25	20,0	16,8	22	M 14	25	24,5	13,0	360	170
16	21	15,00	42	64	85	27	22,0	19,3	22	M 16	28	37,0	16,0	350	230
18	23	16,50	46	71	94	31	25,0	21,8	27	M 18x1,5	32	43,0	19,5	320	320
20	25	18,00	50	77	102	34	27,5	24,3	32	M 20x1,5	33	49,5	23,5	280	415
22	28	20,00	54	84	111	37	30,0	25,8	32	M 22x1,5	37	57,0	29,0	250	540
25	31	22,00	60	94	124	42	33,5	29,6	36	M 24x2	42	68,0	35,0	230	750

Materials:

Housing: up to size 12 turned from free-cutting steel to 9SMnPb28K, 12L13
from size 14 forged from heat-treated steel to C22, M1023

Insert: Special brass to CuZn38Al1

Ball: Bearing steel to 100Cr6, Aisi 52100, hardened, ground, polished

Cetop connections see page 40.